

Conversion of Abdominal Physiological Motion into Electrical Signal Using Pressure Sensor

Mohammed A. Ali omer^{1,2*}, Imad B. Hassen³, ELtahir M. Husain⁴, Mohamed E. Gar-el-nabi¹

¹College of Medical Radiologic Sciences, Sudan University of Science and Technology-Sudan

²College of Applied Medical Science, Department of Radiology, Qassim University, Buraidah-KSA

³School of Electronics Engineering, Sudan University of Science and Technology-Sudan

⁴Department of Biomedical Engineering, Sudan University of Science and Technology-Sudan

Abstract: *The organs motion has been as a matter of challenge for radiation therapy experts; hence the aim of this study was to sense the abdominal motion during breathing and converted into electric signal in order to be mimic and synchronize the organ motion during radiotherapy. The integrated silicon pressure sensor MPX4250 has been constructed and the human breathing pressure has been probed by the sensor and converted into voltage: the generated voltage during inhalation increases from zero (0) volt up to about 5 volts as maximum and the correlation between breathing pressure and the generated volts shows the following equations: $y = 0.02x + 0.26$ (for inhalation) and: $y = -0.02x + 0.26$ for (exhalation). The general breathing mechanism gives a saw tooth curve voltage that could be used to express a synchronized abdominal organs motion during radiotherapy.*

Keywords: Respiration, Bio-signal, Physiology, Sensor, Radiotherapy

1. Introduction

The physiological motion of the abdomen due to breathing (Inspiration and Expiration) induced organs motion during radiation therapy [1-3] and the expansion of the abdominal wall produced by the action of the diaphragm [4-6]. The diaphragm contracts, the abdomen is forced down and forward, and the rib cage is lifted. (b). the intercostals muscles also contract to pull and rotate the ribs, resulting in increasing both the lateral and anterior-posterior (AP) diameters of the thorax [7], such motion during radiation therapy will degrade the efficiency of treatment as well as the prognosis, as the radiation therapy error will not exceeds $\pm 5\%$ [8, 9]. The degradation or this error occur due to that: the growth target volume (GTV) moves partially side away from the radiation field i.e. receiving insufficient radiation dose as well as the critical organ (sensitive organs) could be displaced into the radiation field and will be destroyed by radiation. Therefore, the aim of this paper is to pick up the abdominal physiological motion and converted to electrical signal by using a designed sensor circuit (sensor is a device that detects a change in a physical stimulus and turns it into a signal which can be measured or recorded) [10], in order to be fed to the diaphragm of treatment system (Co-60 teletherapy unit) to synchronize the radiation field size with the movement of the tumor or target volume during radiation therapy. The problem arise due to physiological motion during radiotherapy has been mention by Neicu et al, [11] and George et al, [12] in which they attempted to solve it by converting the infrared reflection to electric signal, however the signal generated is so week, noisy and distorted as seen in Figure (1).

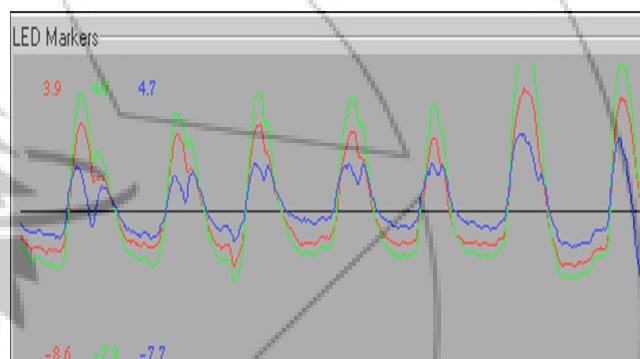

Figure 1: The output Signal of the infrared surface motion reflection. The three curves in each plot correspond to infrared reflector measured patient surface motion in the SI, AP, and ML directions [11, 12]

Other attempt introduced by Sitharama et al, [13] to manage the organ motion problem in radiotherapy was the utilization of innovated real time diaphragm sensor excerpted from the fundamental of net work sensor. On the other hand Seungwoo et al, [14] used a target-tracking radiation-therapy (RT) system that tracks the movement of a treatment target resulting from internal organ movement. The developed radiation-therapy system determines the limit of the MLC (multileaf collimator) movement range with an acquired maximum displacement value of target movement during the radiotherapy planning stage and moves the MLC to continuously detect and synchronize the displacement of the abdominal by using a Charged Coupled Device (CCD) camera monitoring system during real-time RT treatment. In the same realm of trying to manage the problem of respiration motion in radiation therapy, Jun et al, [15] introduce a concept of Synchronized Moving Aperture Radiation Therapy (SMART), that superimposing the tumor motion. The basic idea of SMART is to synchronize the moving radiation beam aperture formed by a dynamic multileaf collimator (DMLC) with the tumor motion induced by respiration; however with this concept a shower of electron being ejected and leading to skin burn.

In this work, the researcher would like to introduce a new idea in radiotherapy field by converting the abdominal motion during breathing into electrical signal using pressure sensor in order to be fed to collimator and synchronize its motion with the target volume during radiotherapy session.

2. Materials

2.1 Piezoelectric Pressure Sensor

Piezoelectric Pressure sensor which is Integrated Silicon Pressure Sensor) is used because of small form factor and high reliability of on-chip integration make the pressure sensor a logical and economical choice for the system design. The piezoelectric effect is electromechanical interaction between the mechanical and the electrical state in crystalline materials with no inversion symmetry [16]. The sensor consists of thin film metallization, and bipolar semiconductor processor to provide an accurate, high level analog output signal which is proportional to the applied pressure. The internal component construction of the piezoelectric sensor is shown in Figure (2).

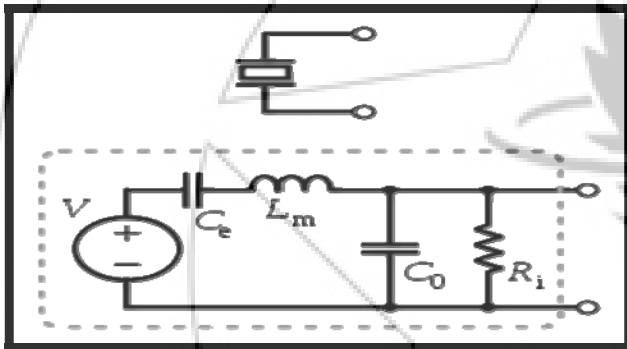

Figure 2: Schematic symbol and electronic model of a piezoelectric sensor

2.2 Signal Conditioning

Signal conditioning means manipulating an analog signal in such a way that it meets the requirements of the next stage for further processing [6], commonly use in analog-to-digital converters ADC. In control engineering applications, it is common to have a sensing stage (which consists of a sensor), a signal conditioning stage (where usually amplification of the signal is done) and a processing stage (normally carried out by an ADC and a micro-controller). Operational amplifiers (op-amps) are commonly employed to carry out the amplification of the signal in the signal conditioning stage. Signal conditioning can include amplification, filtering, converting, range matching, isolation and any other processes required to make sensor output suitable for processing after conditioning [17]. Filtering is the most common signal conditioning function, as usually not all the signal frequency spectrum contains valid data. Figure (3) below shows the internal stages contents of the integrated silicon pressure sensor (sensor + signal conditioning circuit).

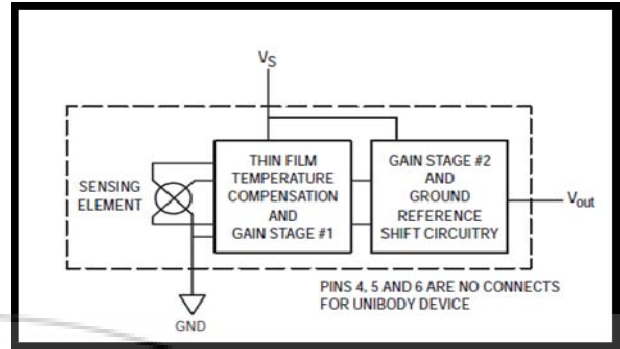

Figure 3: Internal construction stages of the integrated silicon pressure sensor MPX4250, response up to 250 Kpa to generate 5 V as maximum

2.3 Filtering with integrated pressure sensor (IPS)

Figure (4) shows the integrated pressure sensor (IPS) connected to filtering devices for more processing for next stage (Microcontroller).

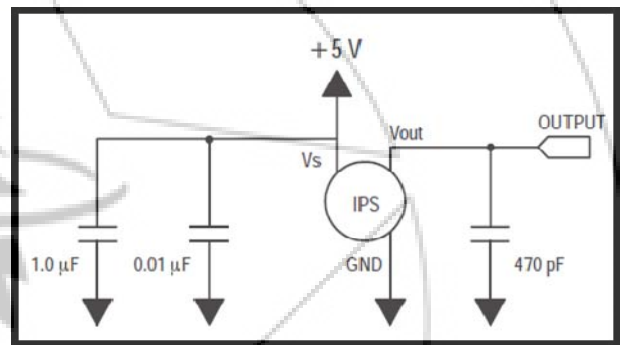

Figure 4: Shows the integrated filtering with integrated pressure sensor (IPS)

3. Method

The pressure sensor element in Figure (3) attached to the chest wall of a volunteered person in a normal breathing rate, hence being stimulated by the breathing action i.e. increasing pressure during inhalation and decreasing pressure during exhalation, an analogue signal voltage has been generated as a result and respectively, and undergoing amplification to increase the resolution of the signal, and its signal-to-noise ratio. Such generated voltage signal has been plotted versus breathing pressure.

4. Results

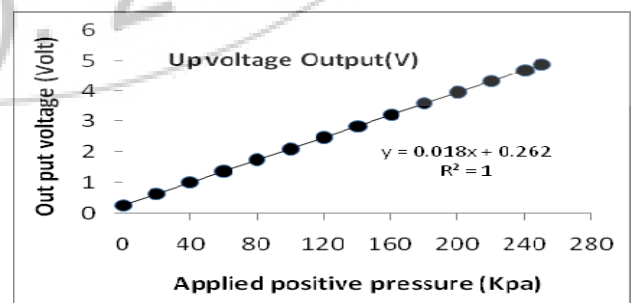

Figure 5: Shows the increasing generated voltage during inhalation

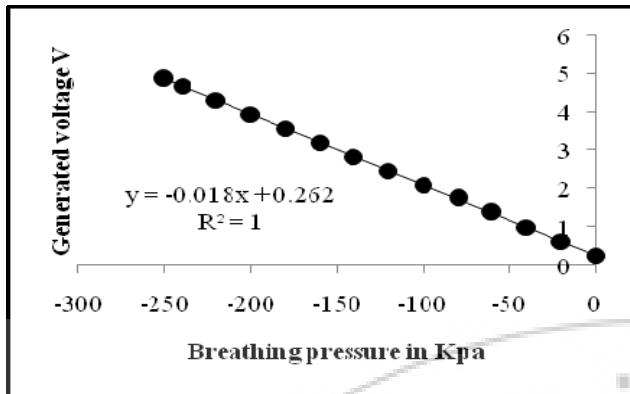

Figure 6: Shows the decreasing generated voltage during exhalation (negative pressure indicates the abdominal wall retracted down by exhalation pressure)

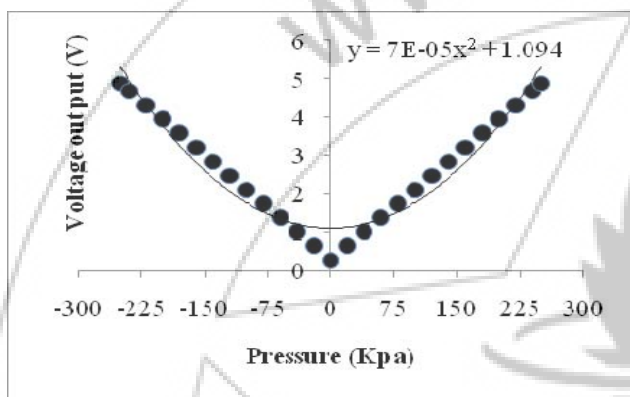

Figure 7: Shows the state of generated voltage during inhalation and exhalation

5. Discussion

Figure (5) shows the generated voltage during inhalation. In which there is increasing generated voltage following the increasing pressure caused by inhalation mechanism, the relationship between the generated voltage and the inhalation pressure could be fitted in the equation of the form: $y = 0.02x + 0.26$, which is so significant as $R^2 = 1$.

Figure (6) shows the decreasing generated voltage during exhalation (negative pressure indicates the abdominal wall retracted down by exhalation pressure). The correlation between the generated voltage and the exhalation pressure could be fitted in the equation of the form: $y = -0.02x + 0.26$, which is significant as $R^2 = 1$. It appears that the generated voltages have equal equation but different direction which indicate and synchronize the mechanism of breathing.

Figure 7 shows the state of generated voltage during inhalation and exhalation. The inhalation generates the positive direction volts and the exhalation generates the negative direction volts and the general relationship showed a polynomial equation of the form: $y = 7E-5x^2 + 1.09$. Such generated voltage could be used to express the mechanism of the breathing and further more to synchronize the abdominal organs motion during radiotherapy, although the breathing pressure will vary from person to another however due to high sensitivity of the integrated silicon pressure sensor, all

the signal range could be detected as breathing pressure and converted to voltage.

6. Conclusions

The physiological motion of the abdomen caused by breathing mechanism could be successfully converted into electrical signal and further more could be utilized to synchronize between abdominal organs motion and the radiotherapy field which is stand as one of radiotherapy problem, with high resolution and high signal to noise ratio which would be matching to next stage of analog digital converter (ADC) by using integrated silicon pressure sensor and then being programmed using (Microcontroller).

References

- [1] Kitamura, K., H. Shirato, Y. Seppenwoolde, R. Onimaru, M. Oda, K. Fujita, S. Shimizu, N. Shinohara, T. Harabayashi, and K. Miyasaka. (2002) "Three-dimensional intrafractional movement of prostate measured during real-time tumor-tracking radiotherapy in supine and prone treatment positions." *Int J Radiat Oncol Biol Phys* 53(5), P: 1117–1123.
- [2] Malone, S., J. M. Crook, W. S. Kendal, and J. Szanto. (2000). "Respiratory-induced prostate motion: quantification and characterization." *Int J Radiat Oncol Biol Phys* 48(1), P: 105–109.
- [3] Weiss, E., H. Vorwerk, S. Richter, and C. F. Hess. (2003). "Interfractional and intrafractional accuracy during radiotherapy of gynecologic carcinomas: A comprehensive evaluation using the ExacTrac system." *Int J Radiat Oncol Biol Phys* 56(1), P: 69–79.
- [4] Gandevia SC, Leeper JB, McKenzie DK, and De Troyer A. (1996). Discharge frequencies of parasternal intercostal and scalene motor units during breathing in normal and COPD subjects. *Am J Resp Crit Care Med*, Vol. 153, P: 622–628.
- [5] Estenne M. and De Troyer A. (1985). Relationship between respiratory muscle electromyogram and rib cage motion in tetraplegia. *Am Rev Respir Dis*. Vol. 132, P: 53–59.
- [6] Sergio Diez, Javier Garcia, Francisco Sendra. (2004). Analysis and evaluation of periodic physiological organ motion in radiotherapy treatments. *Radiotherapy and Oncology* Vol. 73, P: 325–329.
- [7] West, J. B., Baltimore. (1974), *The Essentials of Respiratory Physiology*. Waverly Press, Inc.
- [8] Zhu X R. (2000), Entrance dose measurements for in-vivo diode dosimetry: Comparison of correction factors for two types of commercial silicon diode detectors, *Journal of applied clinical medical physics*, Vol. 1 (3), P: 100-107.
- [9] ICRU (1976). Determination of absorbed dose in a patient irradiated by beams of x-ray or gamma rays in radiotherapy procedures. ICRU report 24, Bethesda, Maryland.
- [10] Gautschi, G (2002). *Piezoelectric Sensorics: Force, Strain, Pressure, Acceleration and Acoustic Emission Sensors, Materials and Amplifiers*. Springer Berlin, Heidelberg, New York.
- [11] Neicu, T., R. Berbeco, J. Wolfgang, and S. B. Jiang.

(2006). "Synchronized moving aperture radiation therapy (SMART): Improvement of breathing pattern reproducibility using respiratory coaching." *Phys Med Biol* 51(3):617–636.

- [12] George, R., S. S. Vedam, T. D. Chung, V. Ramakrishnan, and P. J. Keall. (2005). "The application of the sinusoidal model to lung cancer patient respiratory motion." *Med Phys* 32(9):2850–2861.
- [13] Sitharama S. Lyengar, Nandan P. , Vir V., Phoha, N. Balakrishnan. (2010). *Fundamental of Sensor Network Programming: Application and Technology*, Wiley-IE.EE Press
- [14] Seungwoo Park, Haijo Jung, Kum Bae Kim, Donghan Lee and Young Hoon J. (2009). Development and Evaluation of a Target-tracking Radiation-therapy System Using a Multileaf Collimator (MLC) Synchronized with Moving Organs. *Journal of the Korean Physical Society*, Vol. 55, No. 2, pp. 694 – 701.
- [15] Xu J, Papanikolaou N, Shi C, Jiang S B. (2009). Synchronized moving aperture radiation therapy (SMART): superimposing tumor motion on IMRT MLC leaf sequences under realistic delivery conditions. *Phys Med Biol*. Vol. 54(16), P: 4993-5007.
- [16] Mukti Nath Gupta, Suman and S.K. Yadav. (2014). Electricity Generation Due to Vibration of Moving Vehicles Using Piezoelectric Effect. *Advance in Electronic and Electric Engineering*, Vol. 4, No. 3, P: 313-318.
- [17] Roman Pallas-Arney and John G. Webster. (1991). *Sensors and Signal Conditioning*, John Wiley, New York.

Author Profile



Imad Basheer Hassen Mohammed: Awarded Diploma in Electronic Engineering 1992 from Sudan University of Science and Technology, then Post graduate Diploma in same field and University and M. Sc. in 2003. Has been working as a lecturer since 1992 in SUST and part-timer in many Universities as (Altavana Faculty of Science & Technology (1998-2000), Aurdinia Faculty of Science & Technology (2001 -2004) ans University of medical Science & Technology UMST (2008-2010). Teaching Electronics lab, Electric lab, measurement lab and Radio\T.V maintenance and engineering. Now acting as Ph. D. candidate in SUST.



Mohamed Elfadil M. Gar-elnabi: received the B. Sc. in Radiotherapy and Nuclear Medicine, and M.Sc. degrees in Medical Physics from Sudan University of Science and Technology in 1995 and 2001 respectively. Has been working as medical physicist and radiation technologist at Radiation and Isotopes Center of Khartoum as well as a lecturer at College of Medical Radiologic Science, Sudan University of Science and Technology. Received a Ph. D. degree from Natal University South Africa - 2007 in Medical physics.. Now working as a lecturer (Associate Prof.) at Sudan University of Science and Technology-Khartoum-Sudan.



Eltahir M. Hussein: B. Sc. from Shanghai University, Shanghai china 1980 in Electrical Automation, M. Sc. from University of Gazeera, Sudan 1987 in Solar thermal, Ph.D. from Shanghai University, Shanghai china 1996 in Intelligent Control. Member of several professional organization and now working as Head of Biomedical Engineering Department, college of Engineering, Sudan University of Science and Technology.



Mohammed Ahmed A. Omer: received the B. Sc. -1. in Radiotherapy and Nuclear Medicine, B. Sc.-2 in Medical Equipments Technology and M.Sc. degrees in Medical Physics from Sudan University of Science and Technology in 1995, 1998 and 2001, respectively. Has been working as medical and radiation technologist at Radiation and Isotopes Center of Khartoum as well as a lecturer at College of Medical Radiologic-Sudan Award Ph. D. degree from University Putra Malaysia - 2007 in Medical physics-Applied Radiation. Now working as a lecturer (Associate Prof.) at Qassim University-Buraidah-KSA.